

USB Stereo Turntable System

AT-LP2D-USB

Installation and Operation

Automatic Stereo Turntable System

Installation and Operation



Warning: To prevent fire or shock hazard, do not expose this appliance to rain or moisture.
Attention: Pour prévenir feu ou choc électrique, ne pas exposer l'appareil à la pluie ou à l'humidité.

CAUTION
RISK OF ELECTRIC SHOCK
DO NOT OPEN

AVIS
RISQUE DE CHOC ÉLECTRIQUE
NE PAS OUVRIR



To prevent electric shock, do not remove the cover. There are no user-serviceable parts inside. Internal adjustments are for qualified professionals only. Refer all servicing to qualified service personnel.



Pour prévenir un choc électrique, ne pas ouvrir le couvercle. Il n'y a aucune pièces de rechanges à l'intérieur. Tout ajustement interne doit être fait par une personne qualifié seulement. Référez tout réparation au personnel qualifié.



Caution: To prevent electric shock, do not use the polarized plug with an extension cord, receptacle, or other type of electrical outlet unless the wide blade can be easily inserted into a matching slot.

Attention: Pour éviter toute décharge électrique, ne pas utiliser la prise polarisée avec un cordon de prolongation, réceptacle ou tout autre dispositif électrique, à moins que la broche large puisse s'insérer facilement dans un trou de même taille.

To assure maximum satisfaction from this product, please read the information and follow the instructions presented in this manual. Please keep the manual in an accessible location for future reference.

We suggest that you save all the packaging materials for possible future storage, moving or shipping.

CAUTION: To avoid stylus damage, make certain the included stylus guard is in place whenever the turntable is being installed, moved or cleaned.

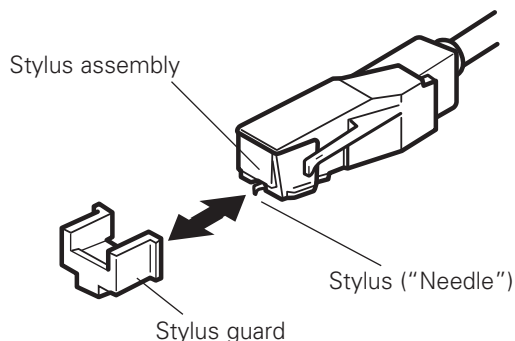

Introduction

Thank you for purchasing the AT-LP2D-USB. Audio-Technica brings its legendary quality and audio fidelity to the digital realm with this LP-to-Digital Recording System. In the box, you'll find everything you need to transfer your classic LP collection to digital files: Audio-Technica's AT-LP2D-USB stereo turntable, complete with USB output that allows direct connection to your computer; recording software—Cakewalk PYRO (for PC use) and Audacity (for MAC or PC); an integral dual-magnet Audio-Technica phono cartridge; a USB cable and adapter cables. The turntable also offers a built-in switchable phono/line preamp that allows connection to a stereo system equipped with either a phono or line-level input.

AT-LP2D-USB stereo turntable features:

- USB output—no special drivers required for direct connection to your computer
- Built-in switchable stereo phono/line level pre-amplifier. Permits use of turntable with stereo systems having either magnetic-phono inputs or "AUX" (line-level) inputs; also allows convenient use of turntable with most powered speakers
- PC & Mac compatible
- Fully automatic operation
- Two speeds: 33 1/3 RPM and 45 RPM
- Professional aluminum turntable platter
- Integral Audio-Technica Dual Magnet™ phono cartridge with replaceable diamond stylus
- Damped lift/cueing mechanism with front-panel control
- Removable dust cover

What's in the box

AT-LP2D-USB Turntable

Removable dust cover

Record mat

Platter

Drive belt

45 RPM adapter

USB cable

Dual RCA (female) to 1/8" (3.5 mm) mini-plug (male) stereo adapter cable

Dual RCA (female) to 1/8" (3.5 mm) mini-plug (female) stereo adapter cable

Cakewalk PYRO software (for PC use only)

Audacity software (for MAC or PC use)

AT-LP2D-USB Turntable Owner's Manual

Software Guide

Controls

Figure 1 Main Features

Front

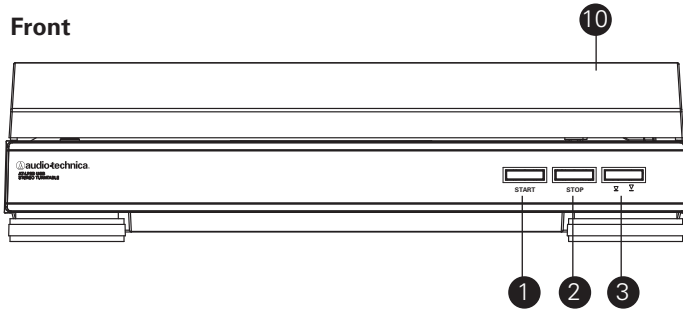

Back

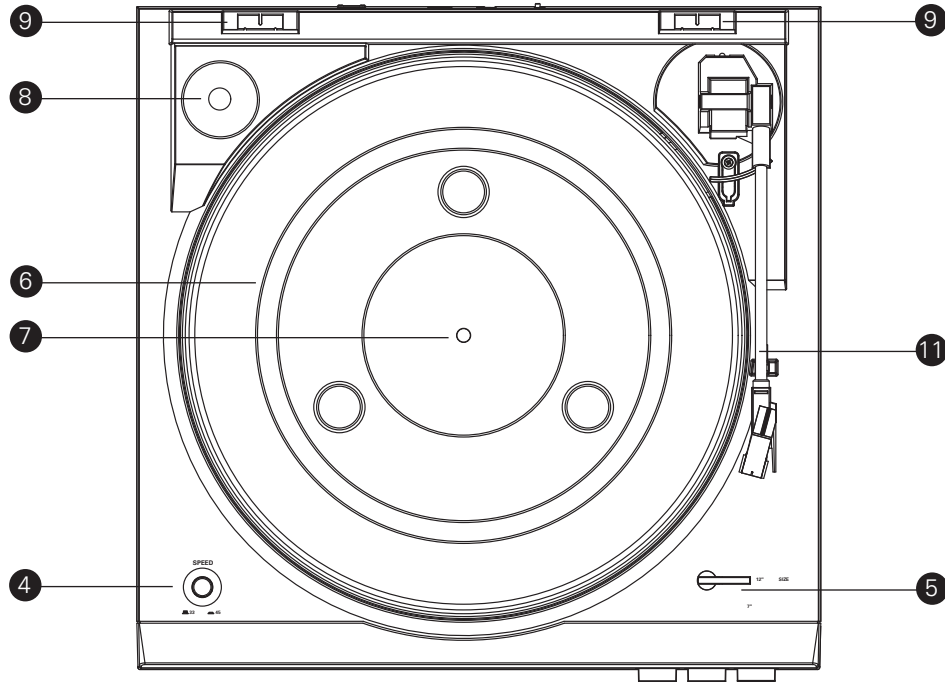
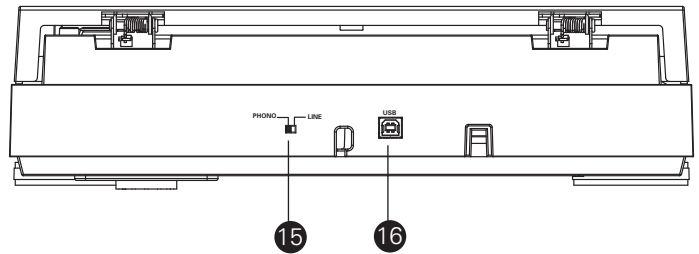

1. **START BUTTON**
Engages the motor/platter and begins automatic operation.
2. **STOP BUTTON**
Disengages the motor/platter and returns tone arm to rest.
3. **TONE ARM LIFT BUTTON**
Lifts and lowers tone arm for manual selection.
4. **PLATTER SPEED BUTTON**
Select 33 RMP (button in high position) or 45 RPM (button in low position) platter speed.
5. **SIZE SELECTOR**
Select the size of the record: 12" or 7".
6. **PLATTER**
Aluminum platter mounts directly to center spindle/motor shaft.
7. **CENTER SPINDLE**
Precision-machined platter-mount portion of the motor shaft.
8. **45-RPM ADAPTER (Shown in receptacle)**
Adapts 7" records with large center holes to fit center spindle.
9. **DUST COVER HINGE HOLDERS**
Attachment points for removable hinged dust cover.
10. **DUST COVER**
11. **TONE ARM/HEADSHELL ASSEMBLY**
Tone arm is permanently attached to the headshell assembly.
12. **STYLUS ASSEMBLY**
13. **STYLUS ("NEEDLE")**
14. **STYLUS GUARD**
15. **PRE-AMP SELECTOR SWITCH (PHONO/LINE)**
(On back of turntable) Use PHONO setting when you connect to the phono input on your home stereo. Use the LINE level when you connect to CD/TAPE/AUX inputs of your home stereo.
16. **USB OUTPUT**
Use this output to connect your turntable to the USB input of your computer. Please see included software guide for instructions.

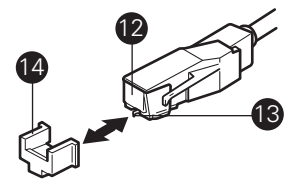

Setup & Operation

Assembling the Turntable

The AT-LP2D-USB requires some assembly before first use. **IMPORTANT:** Do not connect the AC power cord until assembly is complete.

1. Carefully place the turntable platter on the center spindle, making certain the platter is fully seated on the spindle.
2. While holding both ends of the red tape ribbon on the turntable belt, carefully pull the belt over the motor pulley (Fig. 2a). (If the belt drops off, remove the turntable platter and put the belt back on it, as described on page 7.)
3. Once the belt is seated in the pulley's groove, carefully remove the ribbon. Make certain the belt is not twisted.
4. Place the turntable mat on top of the turntable platter (Fig. 2b).
5. If desired, the hinged dust cover may be removed. Hold both sides of the dust cover and pull upward **gently and evenly** to detach the cover from the turntable (Fig. 2c). Keep the cover in a safe, clean place.
6. To re-install the dust cover, guide the dust cover hinges into the two hinge receptacles located at the back of the turntable housing

Connecting to Computers with USB Input

The USB cable (included) connects your AT-LP2D-USB turntable to your computer without need for special drivers. Refer to included software guide (also available online at www.audio-technica.com) before connecting the turntable to your computer.

Setting the Pre-amp (Phono/Line) Switch

For increased flexibility of use, this turntable has an internal stereo phono pre-amplifier. The Pre-amp Selector (Phono/Line) Switch is located on the back of the turntable. If the stereo system you are using has a PHONO input, set the Pre-amp Selector Switch to the "PHONO" position. If your stereo system does not have a PHONO input, set the Pre-amp Selector Switch to the "LINE" position and connect the turntable's output cables to the AUX or other high-level input on your stereo system (described later) (Fig. 3).

NOTE: If you are using the USB cable to connect your turntable to a computer, the Pre-amp Selector Switch setting has no effect on USB operation.

Figure 2 Assembling the Turntable

2a Drive belt

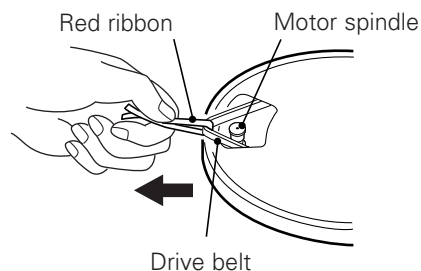

2b Record mat

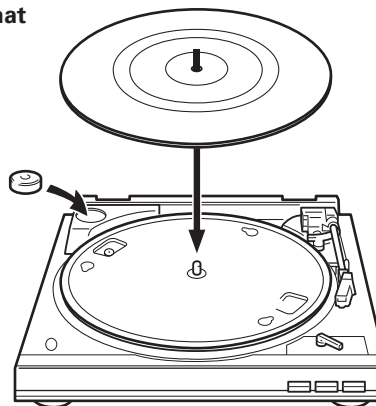

2c Dust cover removal

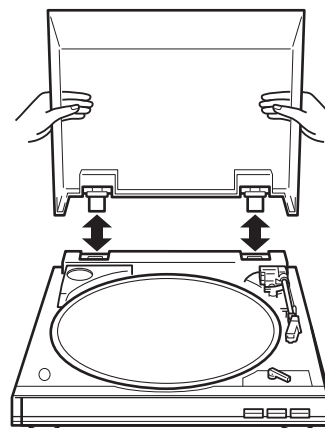
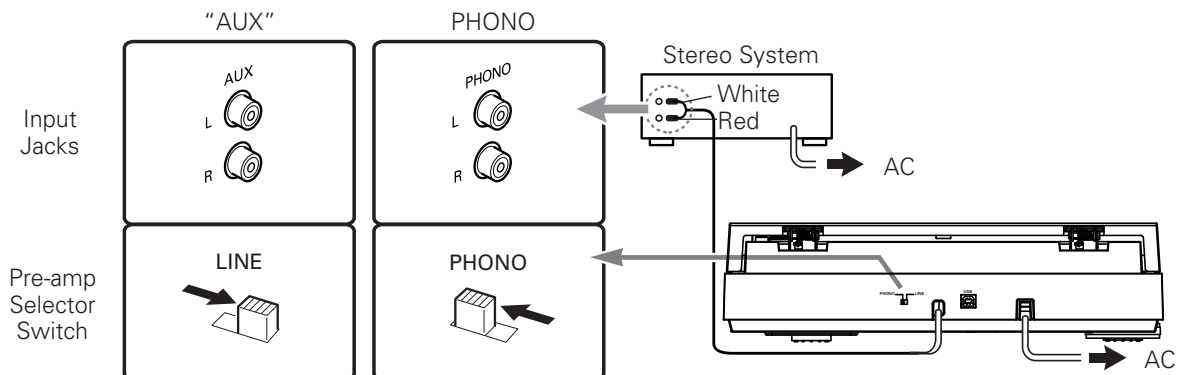

Figure 3



Connecting to Stereo System

1. Connect the red RCA-type pin-plug to the right channel input and the white RCA-type pin-plug to the left channel input of your stereo system (Fig. 3, page 4).
2. With the tone arm still fastened to the tone arm rest, slowly turn the turntable platter **clockwise** ten times, to make certain the automatic mechanism is fully cycled.
3. Remove the vinyl tie that holds the tone arm on its rest.
4. Connect the power cord plug to an AC outlet.
5. NOTE: You do not need to disconnect your turntable from your stereo system in order to connect it to a computer via the USB port. This allows you to monitor your recordings when using recording software. See software guide for further information.

Connecting to Computers or Audio Devices with 3.5 mm Input

The AT-LP2D-USB connects without adapters to devices equipped with RCA connectors. For maximum flexibility, we have included two adapter cables to fit other popular audio inputs.

The first of these adapter cables—dual RCA to stereo 3.5 mm mini-plug (male)—is designed to fit most popular computer* audio inputs. It may also be used to connect the turntable's RCA output to other equipment, including:

- a stereo/boombox* equipped with a 3.5 mm mini input
- powered speakers* equipped with a 3.5 mm mini input
- a mixer* or PA system* equipped with a 3.5 mm mini jack

The second included adapter cable—dual RCA to stereo 3.5 mm mini-plug (female)—permits connection of the turntable output to amplified speakers* or similar devices. The 3.5 mm stereo minijack on the cable adapter accepts stereo mini-plugs.

To use either adapter cable, connect the turntable's red and white RCA-type plugs to the cable adapter's RCA-type jacks.

*** When using either cable adapter, always set the AT-LP2D-USB turntable's Pre-amp Selector Switch to the "LINE" position. (Switch is located on the back of the turntable.)**

NOTE: If connection is desired to a mono amplifier/speaker, make certain to use a stereo-to-mono adapter, available from your dealer or an electronic parts store. Inserting a mono plug in the stereo jack will disable one of the stereo channels. Other adapter cable configurations will be available from dealers and parts stores for connecting to devices needing different terminations.

Operation

Automatic Operation

1. Remove the stylus guard from the stylus assembly (Fig. 4).
2. Put a record on the turntable. If needed, use the 45 RPM adapter (Fig. 5).
3. Select the size of record: 12" or 7" (Fig. 6).
4. Select the speed: 33 $\frac{1}{3}$ RPM or 45 RPM (Fig. 7).
5. **Start:** Gently push the START button (Fig. 8a). The turntable will start and the tone arm automatically will move to the lead-in groove. When the record has finished playing, the tone arm will automatically return to the tone arm rest and the turntable will shut off.
6. **Stop:** To stop playing the record before it reaches the end, press the STOP button (Fig. 8b). The tone arm will lift and return to the tone arm rest, and the turntable will shut off.
7. **Pause:** To pause the record before it has completed playing, press the tone arm Lift button (Fig. 8c). Press the Lift button again to continue playing the record.

Figure 4

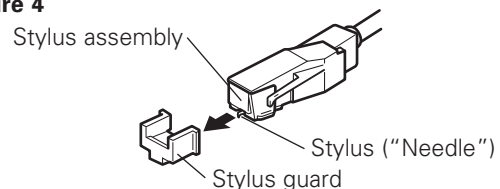
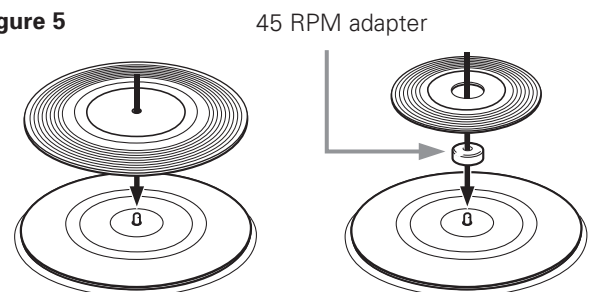

Figure 5



Caution: When the tone arm reaches the end of the record, it will lift and return to the tone arm rest automatically. When this happens, **do not interfere with the tone arm's motion, or damage to the mechanism may occur.**

If the tone arm does not return automatically to the tone arm rest after the record has finished playing, simply press the STOP button to complete operation.

Manual Operation

1. Remove the stylus guard from the stylus assembly (Fig. 4).
2. Put a record on the turntable. If needed, use the 45 RPM adapter (Fig. 5).
3. Select the size of record: 12" or 7" (Fig. 6).
4. Select the speed: 33 $\frac{1}{3}$ PRM or 45 RPM (Fig. 7).
5. Press the Lift button IN to raise the tone arm (Fig. 8c).
3. Gently move the tone arm so the stylus is over the point on the record where play is desired to begin.
4. Press the Lift button again to gently lower the tone arm and play record.

Figure 6

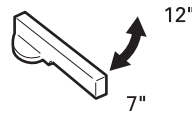

Figure 7

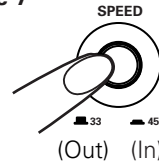

Figure 8

8a



8b



8c

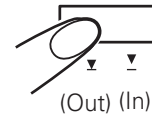

Replacing the Stylus

While holding the head of the tone arm, rotate the front of the stylus assembly in a forward and down motion to remove it (Fig. 9). (As you remove the old assembly, note its position and "feel," to aid in properly installing the new one.)

Install the new stylus assembly as shown in Figures 10a/10b, being careful not to touch the actual stylus. Make certain that the projection at the back of the assembly is fully seated in the cartridge body **first** (Fig. 10a), and that the assembly "clicks" up into place, with no gap between its top edge and the front of the black plastic tone arm head (Fig. 10b). Replace the stylus after 400 hours of use.

To maintain original performance, insist upon a genuine Audio-Technica brand replacement stylus. Look for the Audio-Technica trademark (Ⓐ) on the front of the stylus assembly and on the packaging.

Figure 9 Removing the stylus

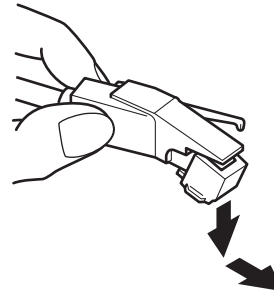
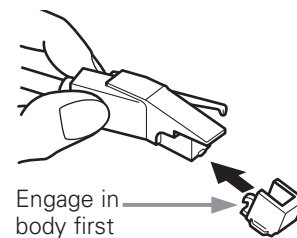
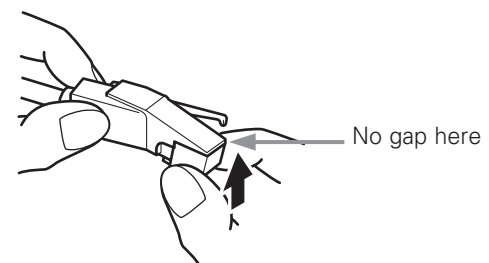

Figure 10 Installing a new stylus

10a



10b



Turntable does not operate

1. Make certain the turntable's AC cord is plugged into an AC outlet, and that the AC outlet is "live."
2. Check the drive belt to make certain it is on correctly. (See Figure 11.)

A) Remove the record mat from the turntable platter (Fig. 11a). Place the mat in the cardboard packaging sleeve for safekeeping. Through an opening in the turntable platter, visually inspect to see if the drive belt is around the motor pulley (Fig. 11b).

B) If the drive belt is not around the motor pulley: Lift and remove the turntable. Place a thumb into each of the left and right openings on the turntable platter; and, using the fingers to press down on the turntable housing's surface, pull the platter **straight up** (Fig. 11c). Avoid pressing on the tone arm.

C) With the turntable platter bottom side up, place the belt along the outside wall of the turntable platter's drive rim, making certain that the belt is smooth and flat all the way around (Fig. 11d).

D) Put the turntable back on the center spindle, make certain it is fully seated, and align one of its openings over the motor pulley position.

E) Through the opening, carefully hook the turntable belt with a finger or with the original red ribbon (**never** use a sharp object) and pull the belt over the motor pulley (Fig. 11e). Make certain the belt is not twisted between the pulley and the platter's drive rim.

F) Put the record mat back on the platter.

G) While holding the tone arm in its rest position, slowly turn the platter by hand clockwise at least 10 rotations to clear the mechanism's automatic cycle.

Figure 11 Checking the drive belt

11a

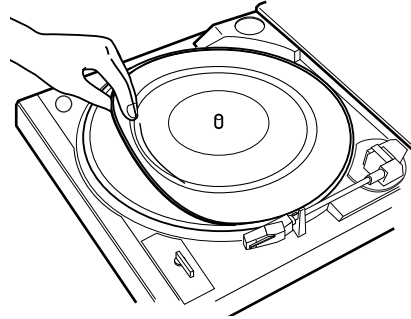

11b

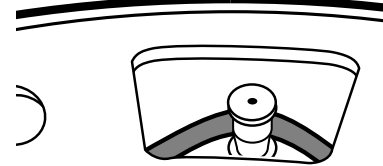

11c

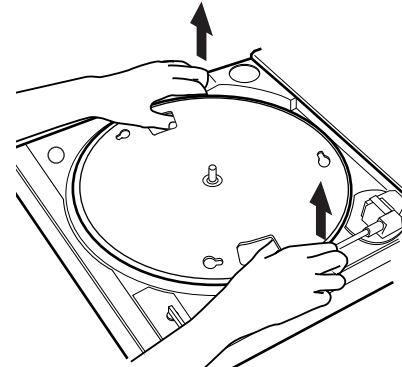

11d

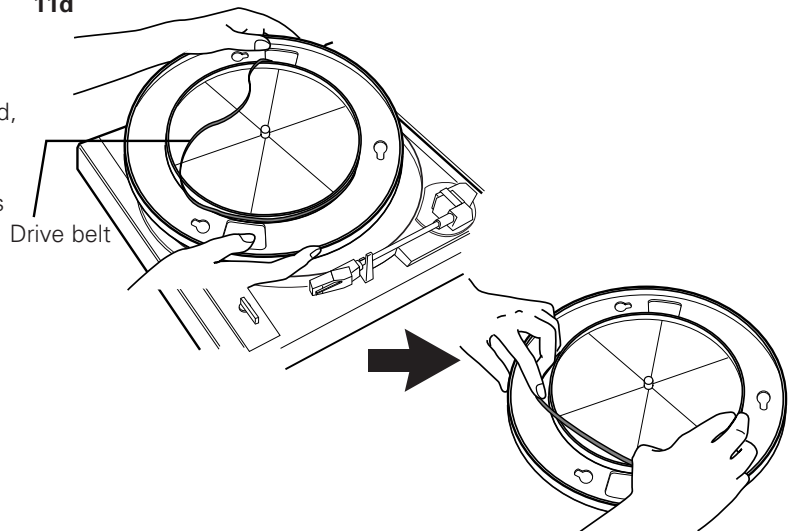

11e

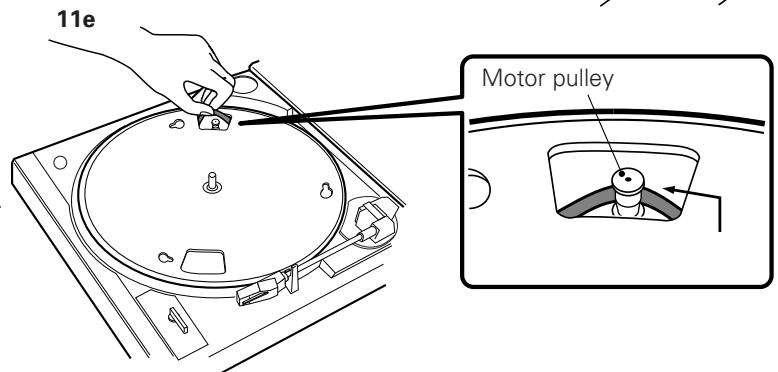

Turntable operates, but no sound at all

1. The stylus guard is still in place.
2. The tone arm Lift button is pressed in.
3. Amplifier controls set incorrectly: wrong input selected, tape monitor on, speakers switched off, etc.
4. Check the stylus on phono cartridge for correct placement. Refer to the instructions for replacing the stylus on page 6.

Turntable operates, but no sound, or sound not loud enough

1. If the turntable is connected to an AUX (high-level) input: The Pre-amp Selector Switch may be set to the "PHONO" position (phono-input level).
2. The input gain of the amplified speaker or similar device may be too low.
3. The stylus assembly may not be fully seated in the cartridge body. (See Fig. 10 on page 6.)

Sound is very distorted

1. Turntable connected to an amplifier's PHONO input: If the pre-amp switch is set to the "LINE" position (AUX high-level output), a phono input will be overloaded.

Turntable moves slightly up and down

1. Usually this is a normal condition and not a problem. If this causes the turntable to be unable to trace the record, please contact your dealer or our service department. **Make very certain the surface upon which the turntable is resting is not picking up vibrations from the floor or walls, or from direct speaker sound.**

Tips For Better Performance

- When opening or closing the turntable cover, handle it gently, moving it either at the center or equally from both sides.
- Do not touch the stylus tip with your fingers; avoid bumping the stylus on the turntable mat or a record's edge.
- Clean the stylus tip frequently, using a soft brush **with a back-to-front motion only**.
- If you use a stylus cleaning fluid, use it **very sparingly**.
- Wipe the dust cover and turntable housing gently with a soft cloth. Use only a small amount of mild detergent solution to clean the turntable and dust cover.
- Never apply harsh chemicals or solvents to any part of the turntable system.
- Prior to moving the turntable, always unplug it from the AC outlet and fasten the tone arm on the tone arm rest with the vinyl twist-tie.

Specifications

Type	Belt drive turntable, fully automatic
Platter	Aluminum
Motor	DC servo-controlled
Speeds	33 $\frac{1}{3}$ RPM, 45 RPM
Wow and flutter	Less than 0.25% (WTD) @ 3K Hz (JIS)
Signal-to-noise ratio	50 dB
Cartridge	Integral Dual Magnet™ stereo cartridge with diamond stylus
Output level	
Pre-amp "PHONO"	2.5 mV nominal at 1 KHz, 5 cm/sec
Pre-amp "LINE"	200 mV nominal at 1 KHz, 5 cm/sec
Power	120V AC, 60 Hz, 3W
Dimensions	14.17" (360 mm) W x 3.82" (97 mm) H x 14.06" (357 mm) D
Net weight	6.6 lbs. (3.4 kg)
Furnished accessories	Dual RCA (female) to 1/8" (3.5 mm) mini-plug (male) stereo adapter cable; dual RCA (female) to 1/8" (3.5 mm) mini-plug (female) stereo adapter cable; USB cable; 45 RPM adapter
Replacement stylus	ATN3600L

Visit our Web Site: www.audio-technica.com

One-Year Limited Warranty

Audio-Technica brand products purchased in the U.S.A. are warranted for one year from date of purchase by Audio-Technica U.S., Inc. (A.T.U.S.) to be free of defects in materials and workmanship. In event of such defect, product will be repaired promptly without charge or, at our option, replaced with a new product of equal or superior value if delivered to A.T.U.S. or an Authorized Service Center, prepaid, together with the sales slip or other proof of purchase date. **Prior approval from A.T.U.S. is required for return.** This warranty excludes defects due to normal wear, abuse, shipping damage, or failure to use product in accordance with instructions. This warranty is void in the event of unauthorized repair or modification, or removal or defacing of the product labeling.

For return approval and shipping information, contact the Service Dept., Audio-Technica U.S., Inc., 1221 Commerce Drive, Stow, Ohio 44224.

Except to the extent precluded by applicable state law, **A.T.U.S. will have no liability for any consequential, incidental, or special damages; any warranty of merchantability or fitness for particular purpose expires when this warranty expires.**

This warranty gives you specific legal rights, and you may have other rights which vary from state to state.

Outside the U.S.A., please contact your local dealer for warranty details.



Audio-Technica U.S., Inc., 1221 Commerce Drive, Stow, Ohio 44224 330/686-2600 www.audio-technica.com

P51983 ©2007 Audio-Technica U.S., Inc. Printed in China